

Grip & Rotate Module - with roller slide

Features

- Grip and rotate functions can be controlled separately
- Grip and rotate, either 90° or 180°, combined in a compact module
- Inside and outside gripping, with stroke of 3 mm per jaw, also available with mechanical grip force safety device
- Low-friction roller slide and double-acting pneumatic cylinder for larger grip forces

Functional diagram

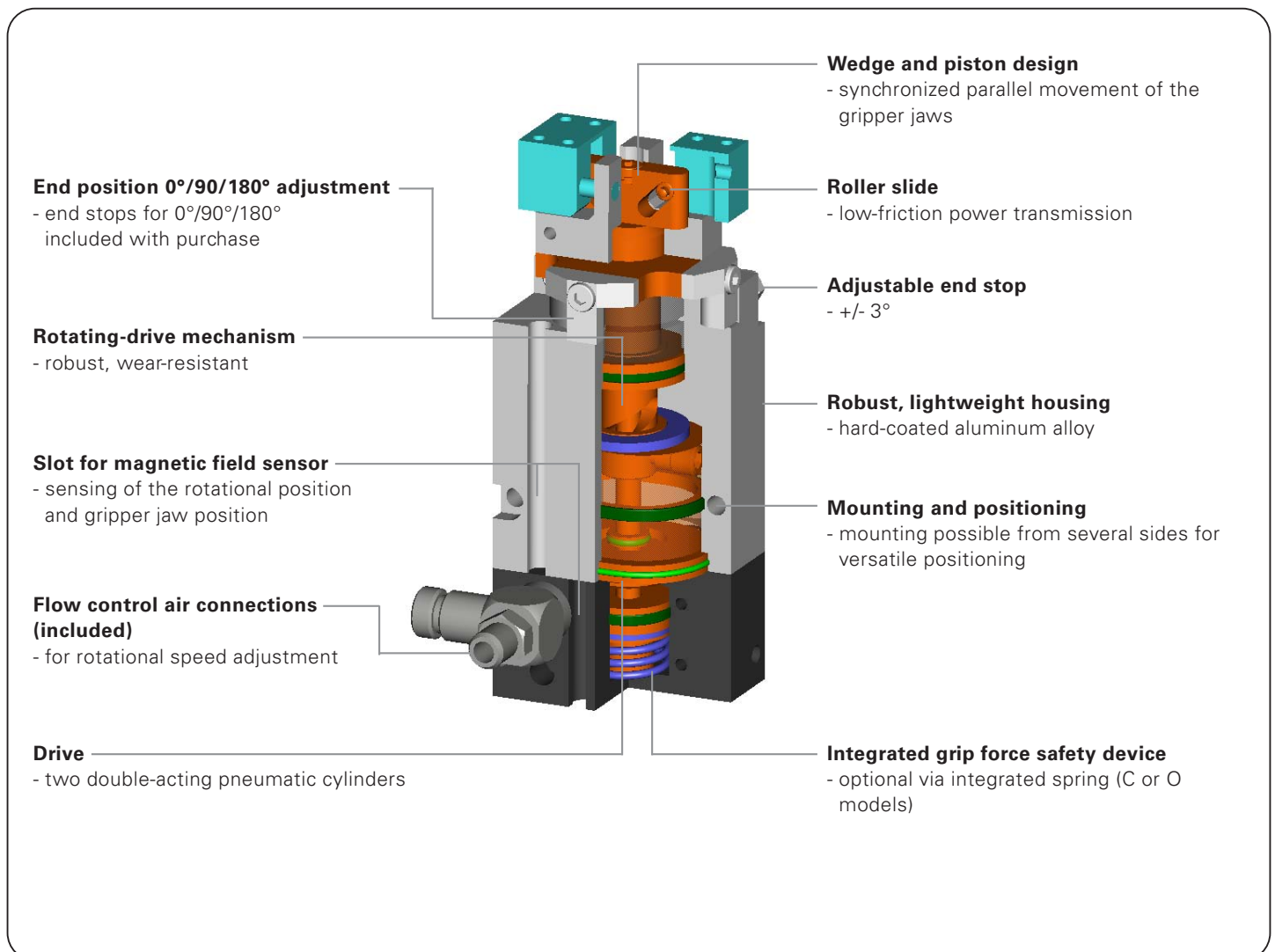

Terms

- Gripping force:** the arithmetic sum of the individual forces occurring at the jaws
- Closing/Opening time:** time required for gripper jaws to cover maximum stroke distance
- Repeatability:** at end stops after 50/100 consecutive cycles
- Cycle:** one complete movement of the piston forward and back
- Maintenance:** recommended at 10 million cycles (please refer to the Operating manual for constraints)
 - low operating costs due to longer maintenance intervals
 - long lifespan

Model guide

- N:** Standard design (long stroke - standard force)
- NC:** Standard design, self-locking, spring closing (long stroke - standard force)
- NO:** Standard design, self-locking, spring opening (long stroke - standard force)

Order No.	Stroke per jaw	Gripping force in opening	Gripping force in closing	Self-locking via	Torque
DGP12N	3 mm	31 N	31 N	DSV*	0.25 Nm
DGP12NC	3 mm	-	52 N	Spring	0.25 Nm
DGP12NO	3 mm	52 N	-	Spring	0.25 Nm

*DSV= Pressure safety valve/one-way valve (Part No. DSV1/8)

Grip & Rotate Module - with roller slide

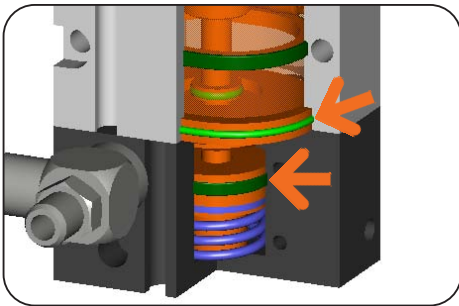

Drive

Gripping

N Models:

Double-acting pneumatic cylinder

- maximum power in both opening and closing
- grip force up to 31 N

NC, NO Models:

Double-acting pneumatic cylinders with integrated spring as mechanical safety device (in the event of pressure loss)

- optimal transmission of power and grip force by spring

Rotation

Double-acting pneumatic cylinder with oval piston

- maximum torque during rotation
- approximately 30% more piston area than with comparable round piston

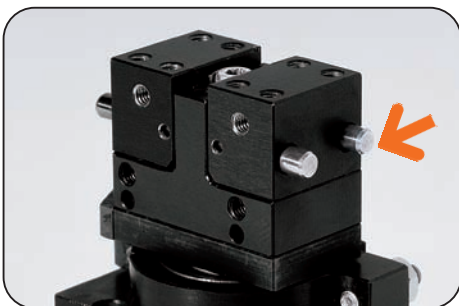

Guidance

Double-roller slide

- hardened steel pin
- jaws made of hard-coated anodized aluminum

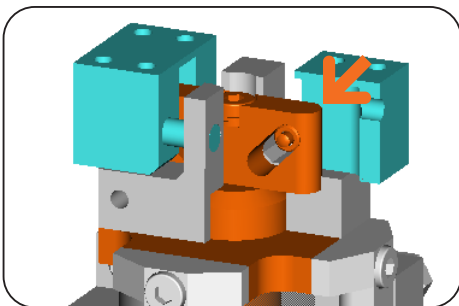

Power transfer

Wedge and piston design with Roller slide

- optimal transmission of power to grip-force
- wear-resistant
- self-centering
- synchronized jaw movement
- high repeatability

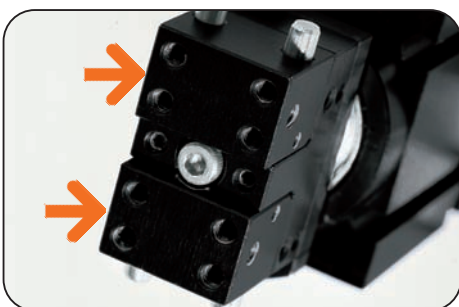

Gripper jaw positioning

Positioning of the tooling via threaded holes

- attachment of tooling fingers



Position sensing

Built-in mount for magnetic field sensors

Sensing of the piston position

- compact – all sensors and cables are outside the swivel area
- stable, separate sensing of the gripping and rotating positions
- for magnetic field sensors with bracket for C-nut

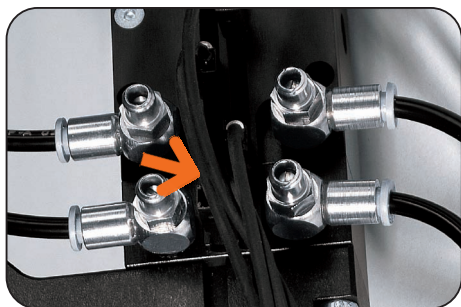

Grip-force safety device

NC, NO Models

Energy retention through spring mounted in cylinder

- reliable mechanical grip-force retention
- compact design

N Models

External pressure-retention safety valve

- grip-force retention through the use of optional pressure retention safety valve (Part No. DSV1/8).

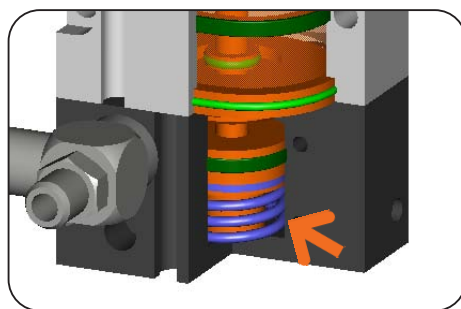

Rotation angle

90° or 180°

Individually adjustable

- simple relocation of end stop
- both stops included in delivery
- easily adaptable from one application to the next

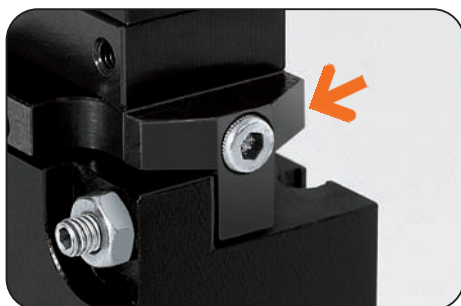

Grip & Rotate Module - with roller slide



Gripping-force diagram

Gripping force as a function of jaw length.

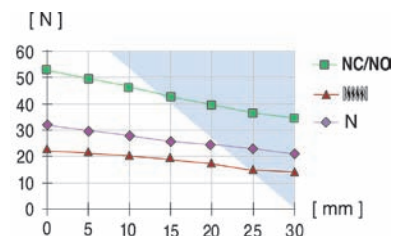

Colored area: increased wear or tear to be expected.

Forces and moments

Max. allowable static forces and moments.

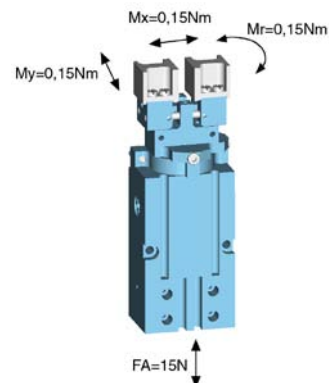

Rotation-time diagram

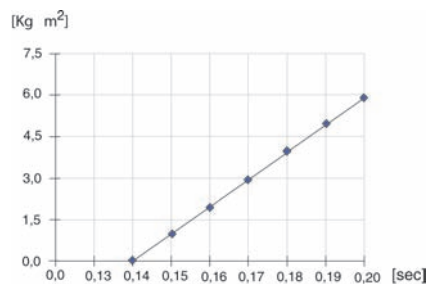

Rotation time as a function of mass moment of inertia.

Included with purchase

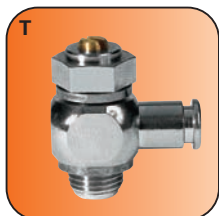

Flow control air fittings
Part No. DRVM5x4



End stop 90° + 180°
Part No. ANS0001

Recommended accessories



Compressed air fittings
(Angled)
Part No. WVM5



Universal jaw set
Part No. UB12 (Al)
Part No. UB12ST (St)

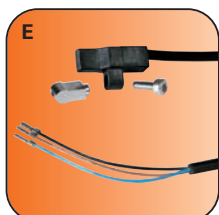

Magnetic field sensor
Part No. MFS103KHC42

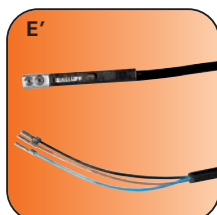

Magnetic field sensor
Part No. MFS303KHC30



Connector 3-plug
Part No. S12-G-3

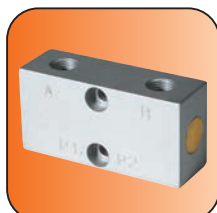

Pressure safety valve/
one-way valve
Part No. DSV1/8

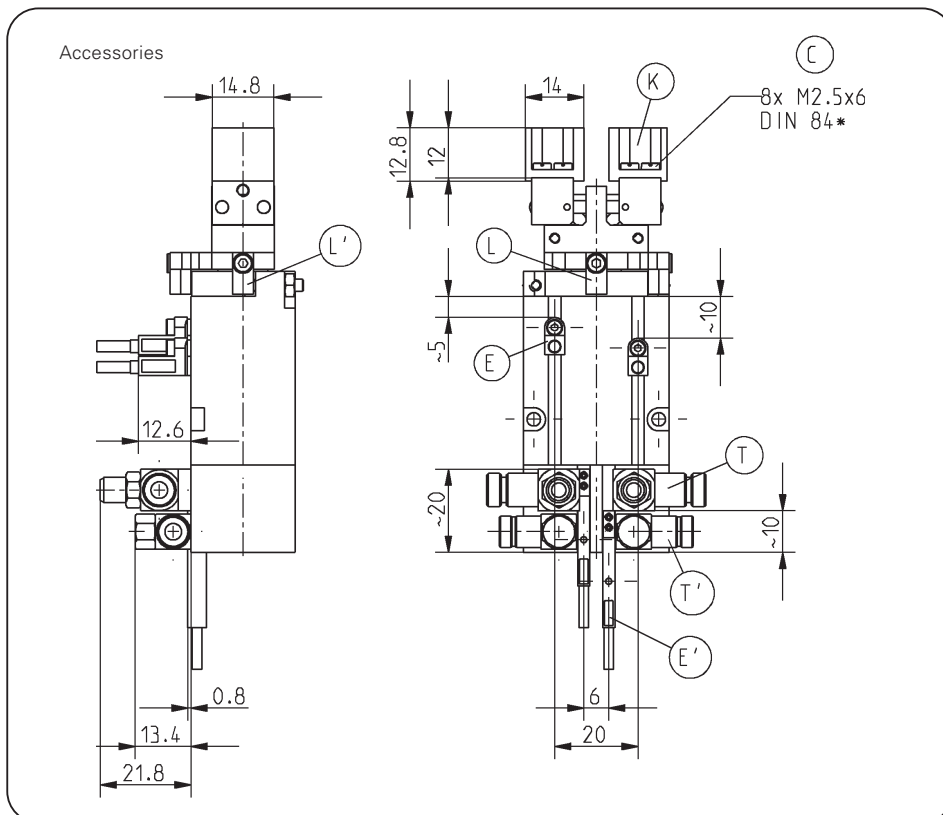

Magnetic field sensor includes bracket

