

Tool changer

WW50	WW80	WW100	WW120	WW180	WW220	WW220E	WW250	HW80	Storage stations	Connectors
------	------	-------	-------	--------------	-------	--------	-------	------	------------------	------------



Sommer-automatic
Grippers
Separators
Swivel units
Rotating jaws
Axial compensators
Tool changers
Linear cylinders
Shock absorbers
Rotary cylinders
Air vane motors
Vacuum components
Accessories
Quick finder



Tool changer

Advantages, benefits, comparisons and tips! Stacks of information all about this product are on page 299.

Order no.:	
WW180	WW180
F	L
Coupling stroke [mm]*:	
-	1,5
Construction height in locked position [mm]**:	
82	82
Handling weight (recommended) max.[kg]:	
180	180
Self-locking via:	
mech.	mech.
Electrical connectors 20 pole ***:	
1x	1x
Electrical connectors (empty):	
1x	1x
Pneumatic connectors 1/8" [pcs.]:	
6	6
Min./max. operating pressure [bar]:	
4/8	4/8
Repeatability ± [mm]:	
0,02	0,02
Air volume per cycle [cm³]:	
90	-
Min./max. operating temperature [C°]:	
5/80	5/80
Weight [kg]:	
3,73	2,12

All data measured at 6 bar.

* with max. axis deviation of 1.5 mm

** incl. adapter panel (loose part)

*** included in shipment (see page 312).

See Page 299 for Accessory list.

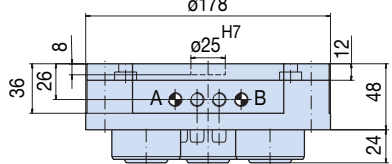
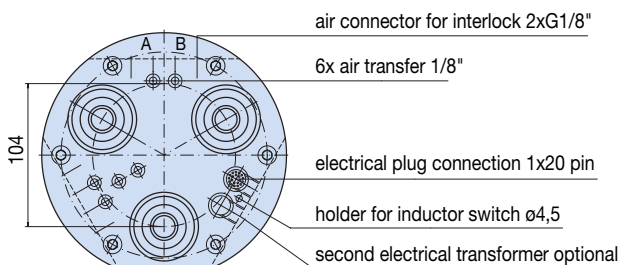

Fixed part

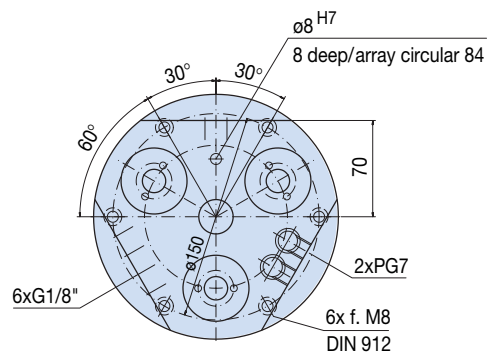
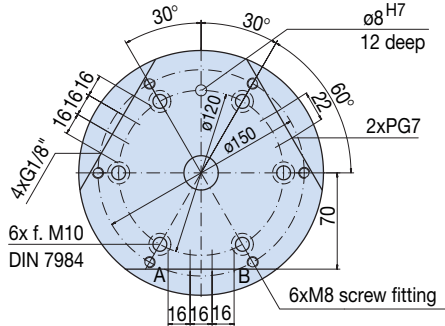

Loose part

