

Parallel Gripper

Three-jaw gripper

Angle gripper

Internal-hole gripper

Other grippers

Electric Gripper

GD530

GD540

GD560



Sommer-automatic

Grippers

Separators

Swivel units

Rotating jaws

Axial compensators

Tool changers

Linear cylinders

Shock absorbers

Rotary cylinders

Air vane motors

Vacuum components

Accessories

Quick finder

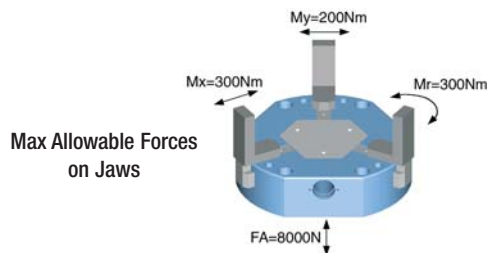

Three-jaw long-stroke gripper with T-slot guide

Advantages, benefits, comparisons and tips! Stacks of information all about this product are on page 124.

Gripping force as a function of jaw length

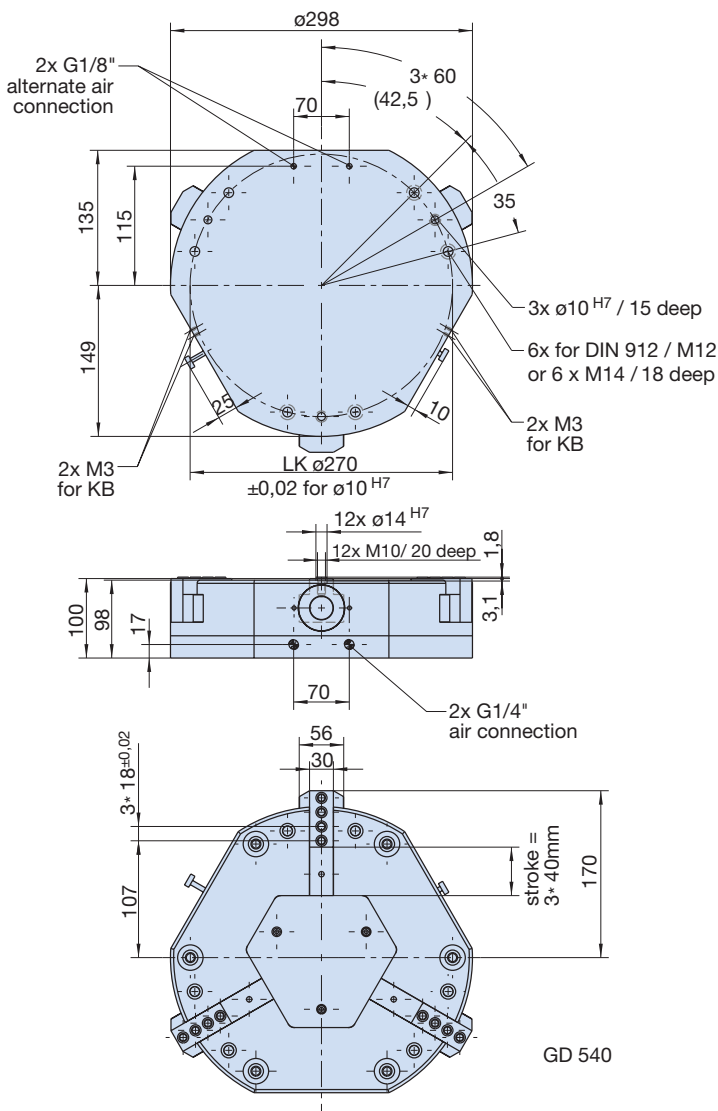
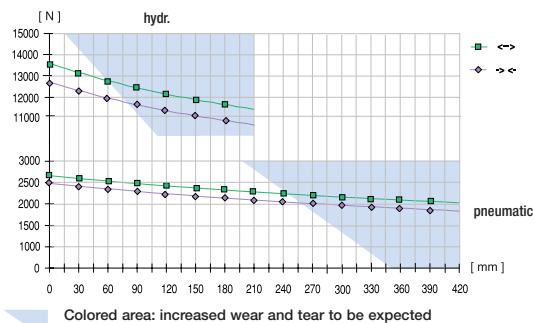

Order no.:	
GD540	GD540
-	H
Drive:	
pneum.	hydr.
Stroke per jaw [mm]:	
40	40
Gripping force in closing and opening [N]:	
2480	12400
Self-locking via:	
DSV 1/8	-
Closing time/opening time [s]:	
0,35	0,6
Repeatability \pm [mm]:	
0,05	0,05
Min./max. operating pressure [bar]:	
3/6	10/40
Air volume per cycle [cm ³]:	
440	-
Oil volume per cycle [cm ³]:	
-	440
Min./max. operating temperature [°C]:	
5-80	5-80
Temp. resistant version up to 150°C [add to part number]	
T6	T6
Piston diameter [mm]:	
45	45
Weight [kg]:	
19,0	19,0

All data measured at 6 bar (hydr. 30 bar).

See Page 124 for Accessory list.