

Parallel gripper **Three-jaw gripper** Angle gripper Internal-hole gripper Other grippers Electric gripper

GD1704 GD1706 GD1708 GD1710 GD1712 GD1716 **GD1720** Universal jaw

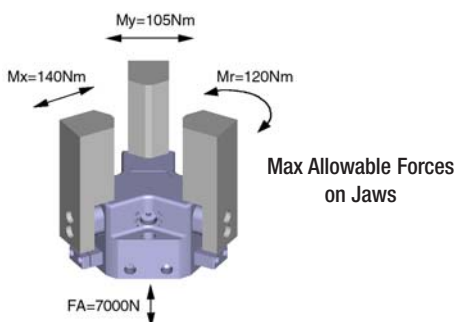

- Sommer-automatic
- Grippers**
- Separators
- Swivel units
- Rotating jaws
- Axial compensators
- Tool changers
- Linear cylinders
- Shock absorbers
- Rotary cylinders
- Air vane motors
- Vacuum components
- Accessories
- Quick finder



Three-jaw gripper with sealed 4-sided guide

Advantages, benefits, comparisons and tips! Stacks of information all about this product are on page 115.

Gripping force as a function of jaw length

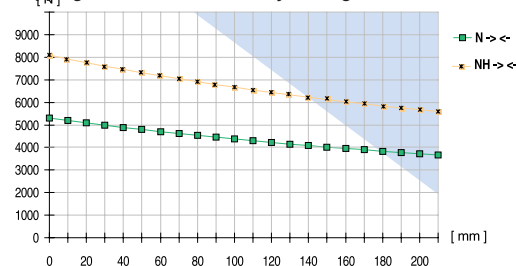

Colored area: increased wear and tear to be expected

Order no.:		GD1720 N	GD1720 NH				
Drive:							
pneum.	hydr.						
Stroke per jaw [mm]:		20	20				
Gripping force in closing [N]:		5250	8100				
Gripping force in opening [N]:		7000	9000				
Self-locking via:		DSV1/8	-				
Closing time/opening time [s]:		0,4	0,7				
Repeatability ± [mm]:		0,05	0,05				
Min./max. operating pressure [bar]:		3/8	10/30				
Air volume per cycle [cm³]:		850	-				
Oil volume per cycle [cm³]:		-	260				
Min./max. operating temperature [°C]:		5/80	5/80				
Temp. resistant version up to 150° C [add to part number]:		T3	T3				
Piston diameter [mm]:		140	85				
Weight [kg]:		12,3	13,2				

All data measured at 6 bar (hydr. 30 bar).

See Page 115 for Accessory list.

