

Parallel gripper **Three-jaw gripper** Angle gripper Internal-hole gripper Other grippers Electric gripper

GD304 GD306 GD308 GD310 **GD312** GD316 GD320 Pressing star Universal jaw

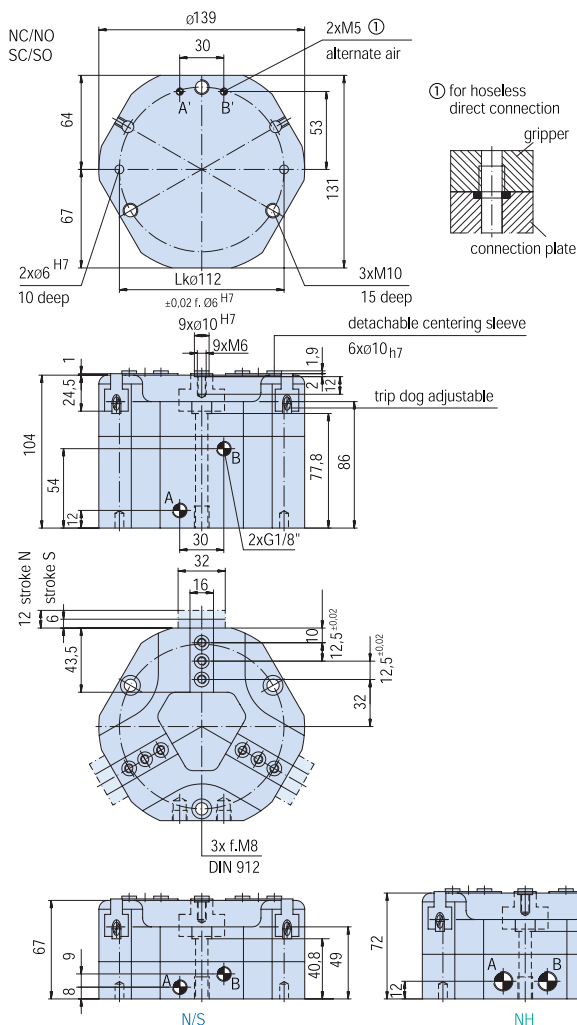

- Sommer-automatic
- Grippers**
- Separators
- Swivel units
- Rotating jaws
- Axial compensators
- Tool changers
- Linear cylinders
- Shock absorbers
- Rotary cylinders
- Air vane motors
- Vacuum components
- Accessories
- Quick finder

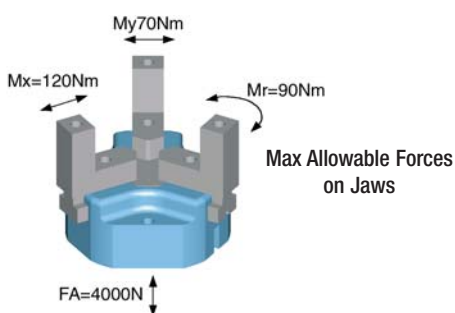

Three-jaw gripper with T-slot guide

Advantages, benefits, comparisons and tips! Stacks of information all about this product are on page 103.

Gripping force as a function of jaw length

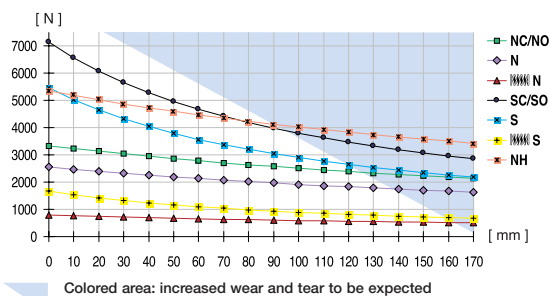

Order no.:						
GD312 N	GD312 NC	GD312 NO	GD312 S	GD312 SC	GD312 SO	GD312 NH
Drive:						
pneum.	pneum.	pneum.	pneum.	pneum.	pneum.	hydr.
Stroke per jaw [mm]:						
12	12	12	6	6	6	12
Gripping force in closing and opening [N]:						
2500	-	-	5500	-	-	5400
Gripping force in closing [N]:						
-	3250	-	-	7000	-	-
Gripping force in opening [N]:						
-	-	3250	-	-	7000	-
Self-locking via:						
DSV1/8	Spring	Spring	DSV1/8	Spring	Spring	-
Closing time/opening time [s]:						
0,12	0,15	0,15	0,12	0,15	0,15	0,6
Repeatability ± [mm]:						
0,05	0,05	0,05	0,05	0,05	0,05	0,05
Min./max. operating pressure [bar]:						
3/8	5/8	5/8	3/8	5/8	5/8	10/40
Air volume per cycle [cm³]:						
162	350	350	162	350	350	-
Oil volume per cycle [cm³]:						
-	-	-	-	-	-	66
Min./max. operating temperature [°C]:						
5/80	5/80	5/80	5/80	5/80	5/80	5/80
Temp. resistant version up to 150° C [add to part number]:						
T2	T2	T2	T2	T2	T2	T2
Piston diameter [mm]:						
83	83	83	83	83	83	55
Weight [kg]:						
3,0	4,8	4,8	3,0	4,8	4,8	3,3

All data measured at 6 bar (hydr. 30 bar).

See Page 103 for Accessory list.

Pressing star available (see page 111).