

Parallel gripper

Three-jaw gripper

Angle gripper

Internal-hole gripper

Other grippers

Electric gripper

SGP14

SGP25

SGP35



Sommer-automatic

Grippers

Separators

Swivel units

Rotating jaws

Axial compensators

Tool changers

Linear cylinders

Shock absorbers

Rotary cylinders

Air vane motors

Vacuum components

Accessories

Quick finder

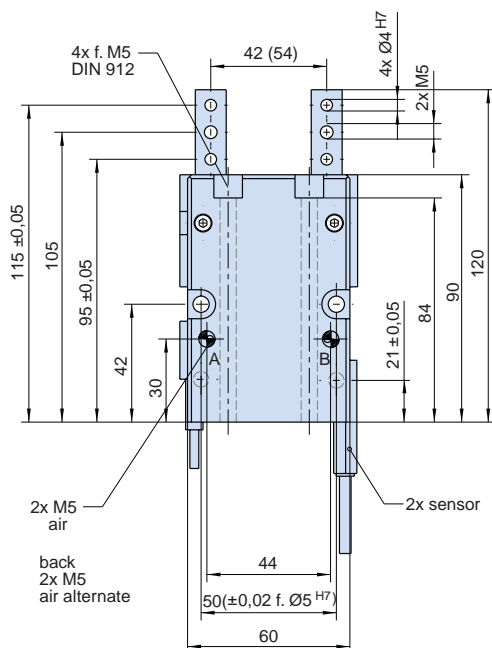
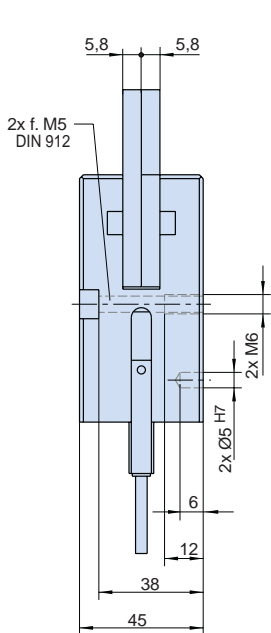
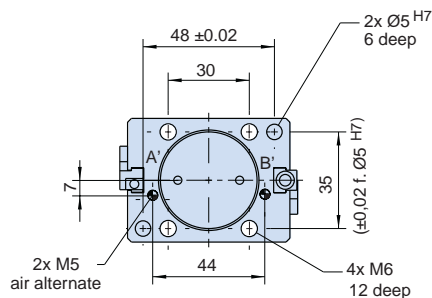
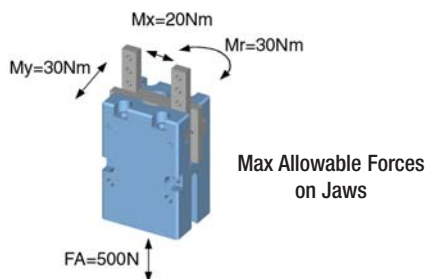

Parallel gripper with flat guide

Advantages, benefits, comparisons and tips! Stacks of information all about this product are on page 100.1

Gripping force as a function of opening angle

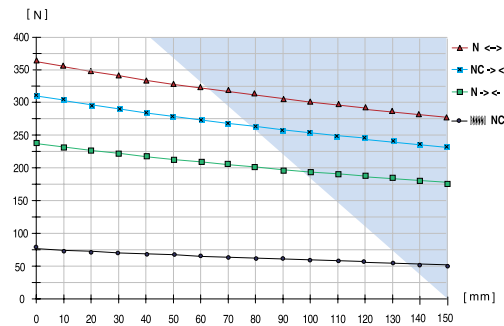

measured from top edge of housing

Order no.:					
SGP35	SGP35				
N	NC				
Drive:					
pneum.	pneum.				
Stroke per jaw [mm]:					
6	6				
Gripping force in closing [N]:					
245	305				
Gripping force in opening [N]:					
305	-				
Self-locking via:					
DSV1/8	Spring				
Closing time/opening time [s]:					
0,05	0,06				
Repeatability ± [mm]:					
0,05	0,05				
Min./max. operating pressure [bar]:					
3/8	5/8				
Air volume per cycle [cm³]:					
14	14				
Min./max. operating temperature. [°C]:					
5/80	5/80				
Temp. resistant version up to 150°C [add to part number]:					
T	T				
Piston diameter [mm]:					
35	35				
Weight [kg]:					
0,45	0,50				

All data measured at 6 bar.

See Page 100.1 for Accessory list.