

Food Gripper GGL3060

NEW
preliminary information!

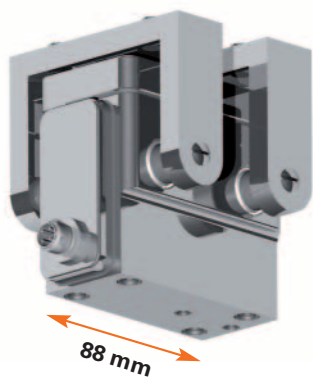

GGL3060NC

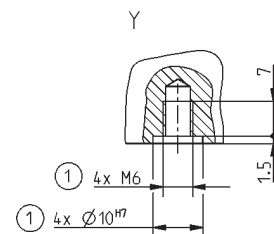
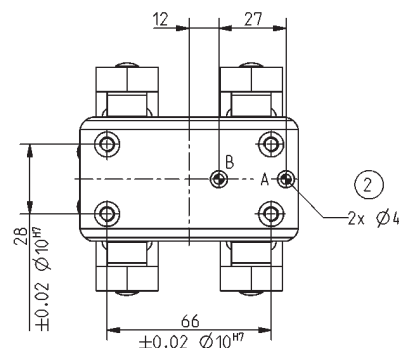

Gripping force diagram

Gripping force as a function of jaw length.

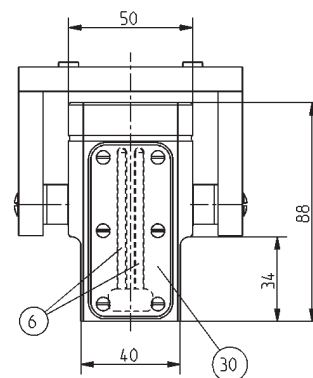
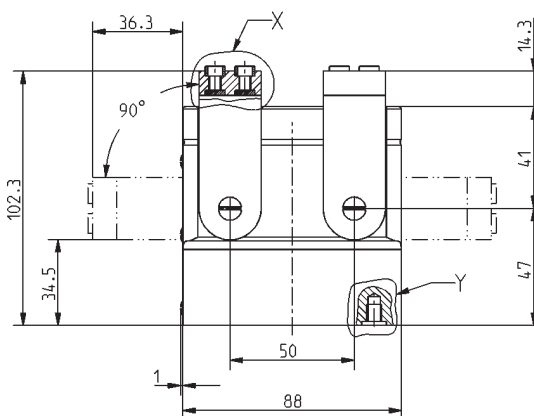
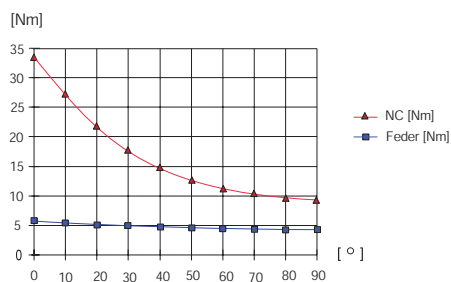

Forces and Moments

Max allowable forces and moments on jaws.

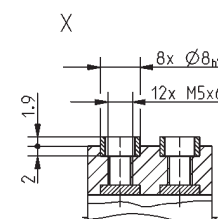
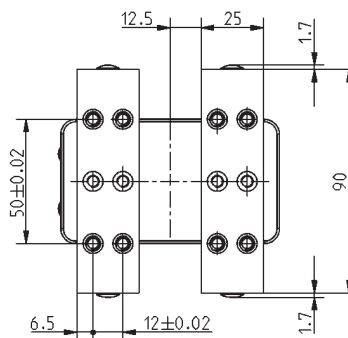
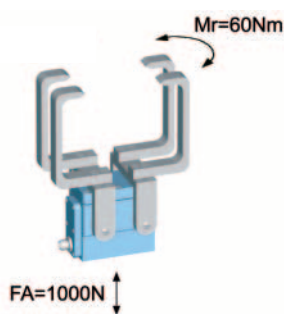

Order no.:	GGL3060NC
Air consumption [cm ³]:	160
Protection class:	IP69K
Material:	1.4301 electro-polished
Seal:	EPDM
Torque [Nm]:	33
Spring torque [Nm]:	6
Weight [kg]:	5,0

Designed under consideration: DIN EN 1672-2

- ① Gripper mounting
- ② Power supply
- ⑥ Slot for nut magnetic field sensor
- ⑩ Cover magnetic field sensor
- Ⓐ Air connection (closing)
- Ⓑ Alternate air connection (opening)

Subject to change without prior notice