

Needle gripper



Features

- 1 Stroke
- 2 Adjusting ring
- 3 Air connection for needle stroke
- 4 Air connection for blowing air
- 5 Needles

Accessories

- 10 Compressed air fitting
- 11 PU-hose



Once upon a time...

Sleeping Beauty, who got pricked by a needle and then fell into a 100-year long sleep. In the meantime, things haven't changed till now! Our Needle Grippers let you handle material you might have considered unworkable - pick up foam sheets, carpets, single pieces of cloth off a stack and much more.

The ST40 has 40 needles arranged into sets of 10 mounted on 4 needle holders. A spring-loaded conical piston lets the needle holders extend radially from the center to tighten the cloth. The depth of needle penetration can be set from 0 - 2 mm with the adjustment ring. When air pressure is removed, the needles are retracted superfast by a spring. A second air connection B is provided to blow away layers of cloth not being picked up, for example, in case of static charges.

The ST36 has 20 needles gripping in two directions and it is smaller than its larger brother ST40. This piston is spring-loaded and a port for blowing air is also available.

The SCH20 loves thick and heavy pieces of cloth, styrofoam, steel, wool, foam rubber, curtain cloth, but also thin carpets, etc.

Four thick needles (1.3 mm in diameter) can grip from 0 to 6 mm deep. The SCH20 is double-acting and it is extended and retracted with compressed air. If these needles are too thin, the 3 mm thick needles of the SCH23 can be ordered.

Note:

On all needle grippers, the needle holders and the needles of the SCH types can be replaced - see "Accessories".

Application Ideas

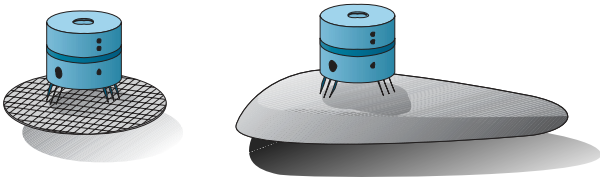

The example shows the cloth gripper ST36 with a filter, with a shoulder pad and really pretty... with a tie.

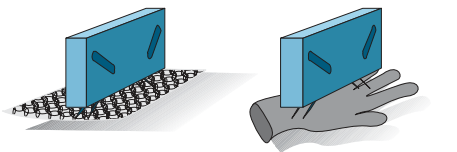
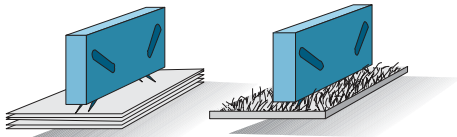
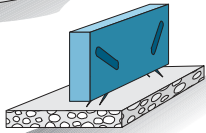
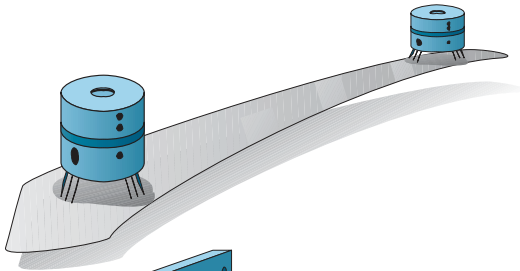

The SCH20 with styrofoam, foam rubber, cardboard; ideal for gripping several layers from a pile, felt, carpets, PVC, mesh fabrics, braided steel (such as butcher's gloves).

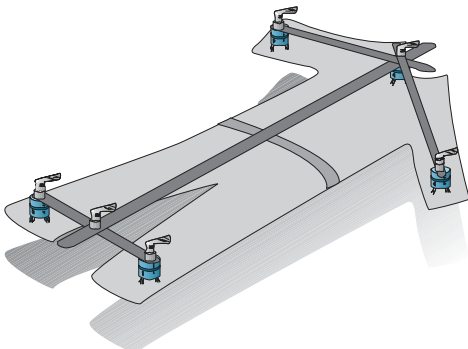

In order to be flexible with different shapes and sizes of textile materials, the fabric grippers can be mounted on a frame so that nearly any position can be reached.

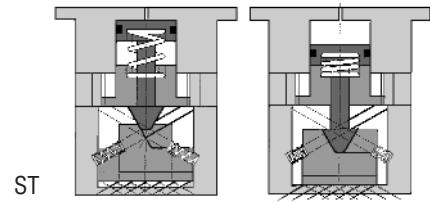
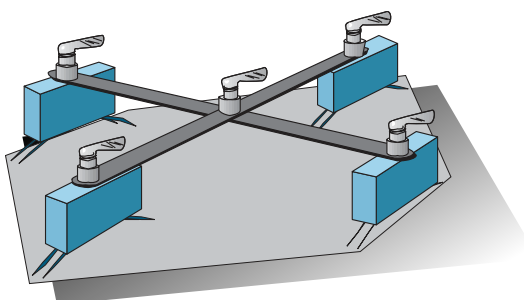

ST

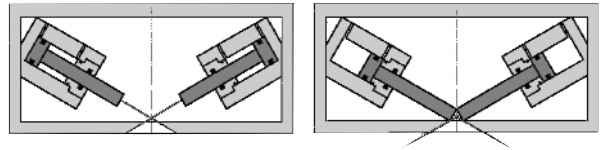

SCH

Operation

A single-acting pneumatic cylinder drives a cone. The needle holders are moved forward and back linearly by the slope of the cone. The extension stroke can be set precisely up to 0.001 mm with a scale. The foam gripper is double-acting and the needle holders are attached directly to the piston.



Parallel gripper		Three-jaw gripper		Angle gripper		Internal-hole gripper		Other grippers			Electric gripper		
SCH20	SCH23	ST36	ST40	ZK22	ZK33	GS65	RG0-30	RG10-60	SPG30-95	GF40	GF41	HM	



Sommer-automatic
Grippers
Separators
Swivel units
Rotating jaws
Axial compensators
Tool changers
Linear cylinders
Shock absorbers
Rotary cylinders
Air vane motors
Vacuum components
Accessories
Quick finder



Needle gripper

Advantages, benefits, comparisons and tips! Stacks of information all about this product are on page 171.

Order no.:	
SCH20	SCH23
Drive	
pneum.	pneum.
Stroke adjustable [mm]:	
0-6	0-6
Number of needles (pcs):	
4	4
Needle diameter [mm]:	
1,3	3
Gripping force in extraction [N]:	
35	35
Self-locking via:	
DSV 1/8	DSV 1/8
Extend/retract time [s]:	
0,02	0,02
Repeatability ± [mm]:	
0,02	0,02
Min./max. operating pressure [bar]:	
4/8	4/8
Air volume per cycle [cm³]:	
5	5
Min./max. operating temperature. [°C]:	
5/80	5/80
temp. resistant version up to 150° C [add to part number]:	
T2	T2
Weight [kg]:	
0,35	0,37

All data measured at 6 bar.

See Page 171 for Accessory list.

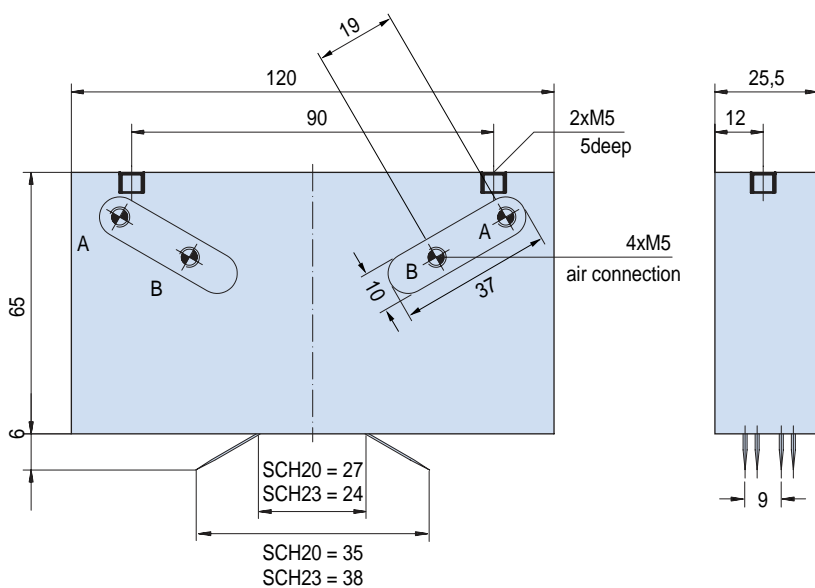

Parallel gripper		Three-jaw gripper		Angle gripper		Internal-hole gripper		Other grippers			Electric gripper		
SCH20	SCH23	ST36	ST40	ZK22	ZK33	GS65	RG0-30	RG10-60	SPG30-95	GF40	GF41	HM	



Needle gripper

Advantages, benefits, comparisons and tips! Stacks of information all about this product are on page 171.



Sommer-automatic
Grippers
Separators
Swivel units
Rotating jaws
Axial compensators
Tool changers
Linear cylinders
Shock absorbers
Rotary cylinders
Air vane motors
Vacuum components
Accessories
Quick finder

Order no.:	
ST36	ST40
Drive	
pneum.	pneum.
Stroke adjustable [mm]:	
0-1,5	0-2
Number of needles (pcs):	
20	40
Needle diameter [mm]:	
0,69	0,69
Gripping force in extraction [N]:	
55	55
Self-locking via:	
DSV 1/8	DSV 1/8
Extend/retract time [s]:	
0,03	0,03
Repeatability ± [mm]:	
0,01	0,01
Min./max. operating pressure [bar]:	
4/8	4/8
Air volume per cycle [cm³]:	
1	3
Min./max. operating temperature. [°C]:	
5/80	5/80
temp. resistant version up to 150° C [add to part number]:	
T1	T1
Weight [kg]:	
0,2	0,5

All data measured at 6 bar.

See Page 171 for Accessory list.

